

# ELI BT A35 V / ELI BT A40 ELI AC A35 V / ELI AC A40

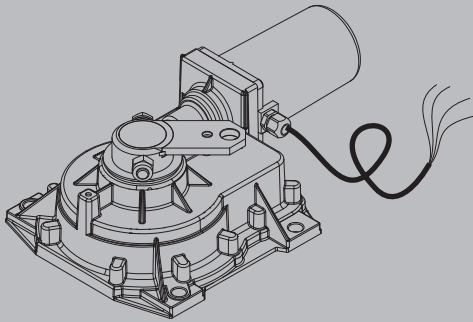

220-230V ~



ELI AC A35 V  
ELI AC A40

24V ≡

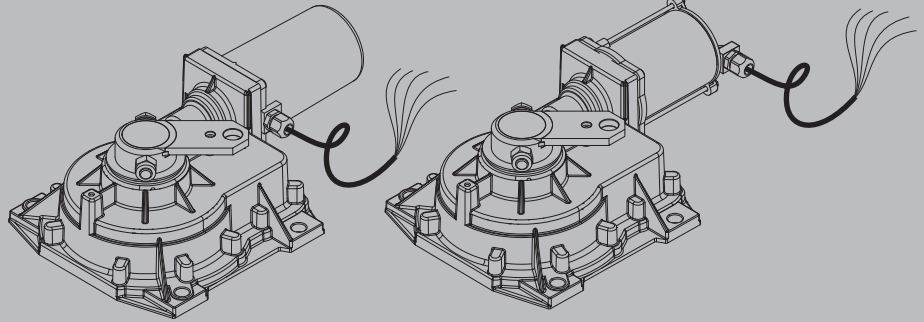

ELI BT A35 V

ELI BT A40

D814057 0AA96\_01 24-06-20

INSTALLATION AND USER'S MANUAL

ELECTROMECHANIC AUTOMATIONS FOR SWING GATES

**Caution!** Read "Warnings" inside carefully!



AZIENDA CON  
SISTEMA DI GESTIONE  
CERTIFICATO DA DNV GL  
= ISO 9001 =  
= ISO 14001 =



**WARNING! Important safety instructions. Carefully read and comply with the Warnings and Instructions that come with the product as improper use can cause injury to people and animals and damage to property. Keep the instructions for future reference and hand them on to any new users.**

**This product is meant to be used only for the purpose for which it was explicitly installed. Any other use constitutes improper use and, consequently, is hazardous. The manufacturer cannot be held liable for any damage as a result of improper, incorrect or unreasonable use.**

### GENERAL SAFETY

Thank you for choosing this product. The Firm is confident that its performance will meet your operating needs.

This product meets recognized technical standards and complies with safety provisions when installed correctly by qualified, expert personnel (professional installer).

If installed and used correctly, the automated system will meet operating safety standards. Nonetheless, it is advisable to observe certain rules of behaviour so that accidental problems can be avoided:

- Keep adults, children and property out of range of the automated system, especially while it is moving.
- Do not allow children to play or stand within range of the automated system.
- The unit can be used by children over 8 years old and by people with reduced physical, sensory or mental capabilities or with no experience or necessary knowledge on condition they are supervised or trained about the safe use of the equipment and understand the risks involved. Children must not play with the unit. Cleaning and maintenance must not be performed by unsupervised children.
- Children must be supervised to ensure they do not play with the device. Do not allow children to play with the fixed controls. Keep remote controls out of reach of children.
- Do not work near hinges or moving mechanical parts.
- Do not hinder the leaf's movement and do not attempt to open the door manually unless the actuator has been released with the relevant release knob.
- Keep out of range of the motorized door or gate while they are moving.
- Keep remote controls or other control devices out of reach of children in order to avoid the automated system being operated inadvertently.
- The manual release's activation could result in uncontrolled door movements if there are mechanical faults or loss of balance.
- When using roller shutter openers: keep an eye on the roller shutter while it is moving and keep people away until it has closed completely. Exercise care when activating the release, if such a device is fitted, as an open shutter could drop quickly in the event of wear or breakage.
- The breakage or wear of any mechanical parts of the door (operated part), such as cables, springs, supports, hinges, guides... , may generate a hazard. Have the system checked by qualified, expert personnel (professional installer) at regular intervals according to the instructions issued by the installer or manufacturer of the door.
- When cleaning the outside, always cut off mains

power.

- Keep the photocells' optics and illuminating indicator devices clean. Check that no branches or shrubs interfere with the safety devices.
- Do not use the automated system if it is in need of repair. In the event the automated system breaks down or malfunctions, cut off mains power to the system; do not attempt to repair or perform any other work to rectify the fault yourself and instead call in qualified, expert personnel (professional installer) to perform the necessary repairs or maintenance. To allow access, activate the emergency release (where fitted).
- If any part of the automated system requires direct work of any kind that is not contemplated herein, employ the services of qualified, expert personnel (professional installer).
- At least once a year, have the automated system, and especially all safety devices, checked by qualified, expert personnel (professional installer) to make sure that it is undamaged and working properly.
- A record must be made of any installation, maintenance and repair work and the relevant documentation kept and made available to the user on request.
- Failure to comply with the above may result in hazardous situations.



### SCRAPPING

Materials must be disposed of in accordance with the regulations in force. Do not throw away your discarded equipment or used batteries with household waste. You are responsible for taking all your waste electrical and electronic equipment to a suitable recycling centre.

**Anything that is not explicitly provided for in the user guide is not allowed. The operator's proper operation can only be guaranteed if the instructions given herein are complied with. The Firm shall not be answerable for damage caused by failure to comply with the instructions featured herein.**

**While we will not alter the product's essential features, the Firm reserves the right, at any time, to make those changes deemed opportune to improve the product from a technical, design or commercial point of view, and will not be required to update this publication accordingly.**

## INSTALLER WARNINGS

**WARNING! Important safety instructions. Carefully read and comply with all the warnings and instructions that come with the product as incorrect installation can cause injury to people and animals and damage to property. The warnings and instructions give important information regarding safety, installation, use and maintenance. Keep hold of instructions so that you can attach them to the technical file and keep them handy for future reference.**

### GENERAL SAFETY

This product has been designed and built solely for the purpose indicated herein. Uses other than those indicated herein might cause damage to the product and create a hazard.

- The units making up the machine and its installation must meet the requirements of the following European Directives, where applicable: 2014/30/UE, 2014/35/UE, 2006/42/UE, 2011/305/UE, 2014/53/UE and later amendments. For all countries outside the UE, it is advisable to comply with the standards mentioned, in addition to any national standards in force, to achieve a good level of safety.
- The Manufacturer of this product (hereinafter referred to as the "Firm") disclaims all responsibility resulting from improper use or any use other than that for which the product has been designed, as indicated herein, as well as for failure to apply Good Practice in the construction of entry systems (doors, gates, etc.) and for deformation that could occur during use.
- Installation must be carried out by qualified personnel (professional installer, according to EN 12635), in compliance with Good Practice and current code.
- Before installing the product, make all structural changes required to produce safety gaps and to provide protection from or isolate all crushing, shearing and dragging hazard areas and danger zones in general in accordance with the provisions of standards EN 12604 and 12453 or any local installation standards. Check that the existing structure meets the necessary strength and stability requirements.
- Before commencing installation, check the product for damage.
- The Firm is not responsible for failure to apply Good Practice in the construction and maintenance of the doors, gates, etc. to be motorized, or for deformation that might occur during use.
- Make sure the stated temperature range is compatible with the site in which the automated system is due to be installed.
- Do not install this product in an explosive atmosphere: the presence of flammable fumes or gas constitutes a serious safety hazard.
- Disconnect the electricity supply before performing any work on the system. Also disconnect buffer batteries, if any are connected.
- Before connecting the power supply, make sure the product's ratings match the mains ratings and that a suitable residual current circuit breaker and overcurrent protection device have been installed upline from the electrical system. Have the automated system's mains power supply fitted with a switch or omnipolar thermal-magnetic circuit breaker with a contact separation that provide full disconnection under overvoltage category III conditions.
- Make sure that upline from the mains power supply there is a residual current circuit breaker that trips at no more than 0.03A as well as any other equipment required by code.
- Make sure the earth system has been installed correctly: earth all the metal parts belonging to the entry system (doors, gates, etc.) and all parts of the system featuring an earth terminal.
- Installation must be carried out using safety devices and controls that meet standards EN 12978 and EN 12453.
- Impact forces can be reduced by using deformable edges.
- In the event impact forces exceed the values laid down by the relevant standards, apply electro-sensitive or pressure-sensitive devices.
- Apply all safety devices (photocells, safety edges, etc.) required to keep the area free of impact, crushing, dragging and shearing hazards. Bear in mind the standards and directives in force, Good Practice criteria, intended use, the installation environment, the operating logic of the system and forces generated by the automated system.
- Apply all signs required by current code to identify hazardous areas (residual risks). All installations must be visibly identified in compliance with the provisions of standard EN 13241-1.
- Once installation is complete, apply a nameplate featuring the door/gate's data.
- This product cannot be installed on leaves incorporating doors (unless the motor can be activated only when the door is closed).
- If the automated system is installed at a height of less than 2.5 m or is accessible, the electrical and mechanical parts must be suitably protected.
- For roller shutter automation only
  - 1) The motor's moving parts must be installed at a height greater than 2.5 m above the floor or other surface from which they may be reached.
  - 2) The gearmotor must be installed in a segregated and suitably protected space so that it cannot be reached without the aid of tools.
- Install any fixed controls in a position where they will not cause a hazard, away from moving parts. More specifically, hold-to-run controls must be positioned within direct sight of the part being controlled and, unless they are key operated, must be installed at a height of at least 1.5 m and in a place where they cannot be reached by the public.
- Apply at least one warning light (flashing light) in a visible position, and also attach a Warning sign to the structure.
- Attach a label near the operating device, in a permanent fashion, with information on how to operate the automated system's manual release.
- Make sure that, during operation, mechanical risks are avoided or relevant protective measures taken and, more specifically, that nothing can be banged, crushed, caught or cut between the part being operated and surrounding parts.
- Once installation is complete, make sure the motor automation settings are correct and that the safety and release systems are working properly.
- Only use original spare parts for any maintenance or repair work. The Firm disclaims all responsibility for the correct operation and safety of the automated system if parts from other manufacturers are used.
- Do not make any modifications to the automated system's components unless explicitly authorized by the Firm.
- Instruct the system's user on what residual risks may be encountered, on the control systems that have been applied and on how to open the system manually in an emergency. Give the user guide to the end user.

-Dispose of packaging materials (plastic, cardboard, polystyrene, etc.) in accordance with the provisions of the laws in force. Keep nylon bags and polystyrene out of reach of children.

### WIRING

**WARNING!** For connection to the mains power supply, use: a multicore cable with a cross-sectional area of at least 5x1.5mm<sup>2</sup> or 4x1.5mm<sup>2</sup> when dealing with three-phase power supplies or 3x1.5mm<sup>2</sup> for single-phase supplies (by way of example, type H05RN-F cable can be used with a cross-sectional area of 4x1.5mm<sup>2</sup>). To connect auxiliary equipment, use wires with a cross-sectional area of at least 0.5 mm<sup>2</sup>.

- Only use pushbuttons with a capacity of 10A-250V or more.
- Wires must be secured with additional fastening near the terminals (for example, using cable clamps) in order to keep live parts well separated from safety extra low voltage parts.
- During installation, the power cable must be stripped to allow the earth wire to be connected to the relevant terminal, while leaving the live wires as short as possible. The earth wire must be the last to be pulled taut in the event the cable's fastening device comes loose.

**WARNING!** safety extra low voltage wires must be kept physically separate from low voltage wires.

Only qualified personnel (professional installer) should be allowed to access live parts.

### CHECKING THE AUTOMATED SYSTEM AND MAINTENANCE

Before the automated system is finally put into operation, and during maintenance work, perform the following checks meticulously:

- Make sure all components are fastened securely.
- Check starting and stopping operations in the case of manual control.
- Check the logic for normal or personalized operation.
- For sliding gates only: check that the rack and pinion mesh correctly with 2 mm of play along the full length of the rack; keep the track the gate slides on clean and free of debris at all times.
- For sliding gates and doors only: make sure the gate's running track is straight and horizontal and that the wheels are strong enough to take the weight of the gate.
- For cantilever sliding gates only: make sure there is no dipping or swinging during operation.
- For swing gates only: make sure the leaves' axis of rotation is perfectly vertical.
- For barriers only: before opening the door, the spring must be decompressed (vertical boom).
- Check that all safety devices (photocells, safety edges, etc.) are working properly and that the anti-crush safety device is set correctly, making sure that the force of impact measured at the points provided for by standard EN 12445 is lower than the value laid down by standard EN 12453.
- Impact forces can be reduced by using deformable edges.
- Make sure that the emergency operation works, where this feature is provided.
- Check opening and closing operations with the control devices applied.
- Check that electrical connections and cabling are intact, making extra sure that insulating sheaths and cable glands are undamaged.
- While performing maintenance, clean the photocells' optics.
- When the automated system is out of service for any length of time, activate the emergency release (see "EMERGENCY OPERATION" section) so that the operated part is made idle, thus allowing the gate to be opened and closed manually.
- If the power cord is damaged, it must be replaced by the manufacturer or their technical assistance department or other such qualified person to avoid any risk.
- If "D" type devices are installed (as defined by EN12453), connect in unverified mode, foresee mandatory maintenance at least every six months
- The maintenance described above must be repeated at least once yearly or at shorter intervals where site or installation conditions make this necessary.

### WARNING!

Remember that the drive is designed to make the gate/door easier to use and will not solve problems as a result of defective or poorly performed installation or lack of maintenance



### SCRAPPING

Materials must be disposed of in accordance with the regulations in force. Do not throw away your discarded equipment or used batteries with household waste. You are responsible for taking all your waste electrical and electronic equipment to a suitable recycling centre.

### DISMANTLING

If the automated system is being dismantled in order to be reassembled at another site, you are required to:

- Cut off the power and disconnect the whole electrical system.
- Remove the actuator from the base it is mounted on.
- Remove all the installation's components.
- See to the replacement of any components that cannot be removed or happen to be damaged.

**DECLARATIONS OF CONFORMITY CAN BE FOUND AT <http://www.bft-automation.com/CE>  
INSTRUCTIONS FOR USE AND ASSEMBLY CAN BE FOUND IN THE DOWN-LOAD SECTION.**

**Anything that is not explicitly provided for in the installation manual is not allowed. The operator's proper operation can only be guaranteed if the information given is complied with. The Firm shall not be answerable for damage caused by failure to comply with the instructions featured herein.**

**While we will not alter the product's essential features, the Firm reserves the right, at any time, to make those changes deemed opportune to improve the product from a technical, design or commercial point of view, and will not be required to update this publication accordingly.**

### GENERAL INFO

The electromechanical actuator **ELI BT A35 V - ELI BT A40 - ELI AC A35 V - ELI AC A40** is the ideal solution for sub-hinge underfloor applications. The actuator is made with a single, watertight mono-block reducer. The sub-hinge position maintains the gate's aesthetics intact and makes the automation practically invisible. Once the support casing is installed, the gate is operative even without mounting the actuator, which can be assembled subsequently.

### PREPARATION OF CABLES

## ELI BT A

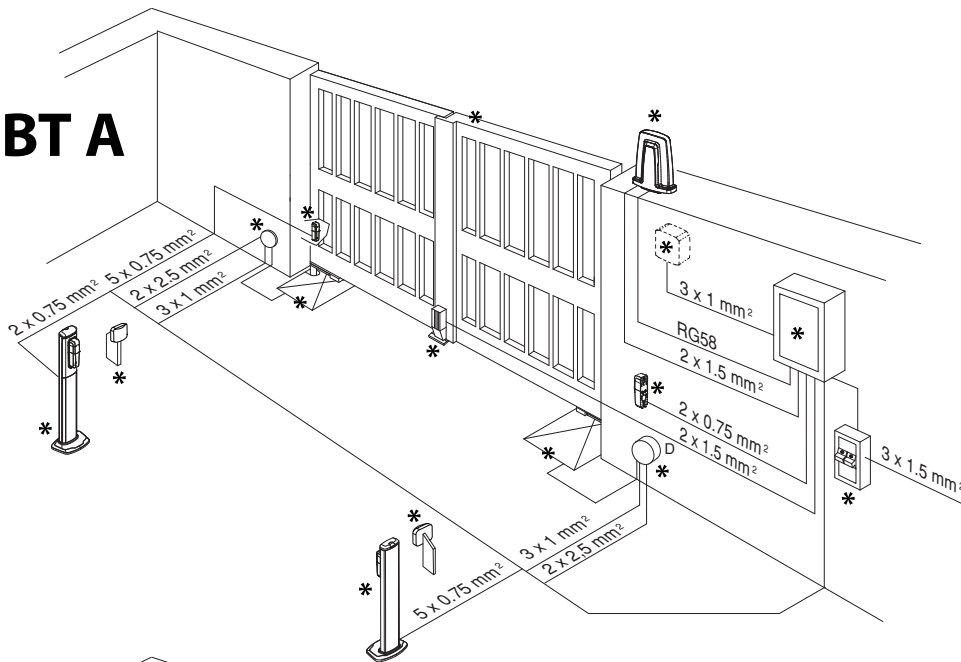

Only for use with limit-switch accessory

## ELI ACA

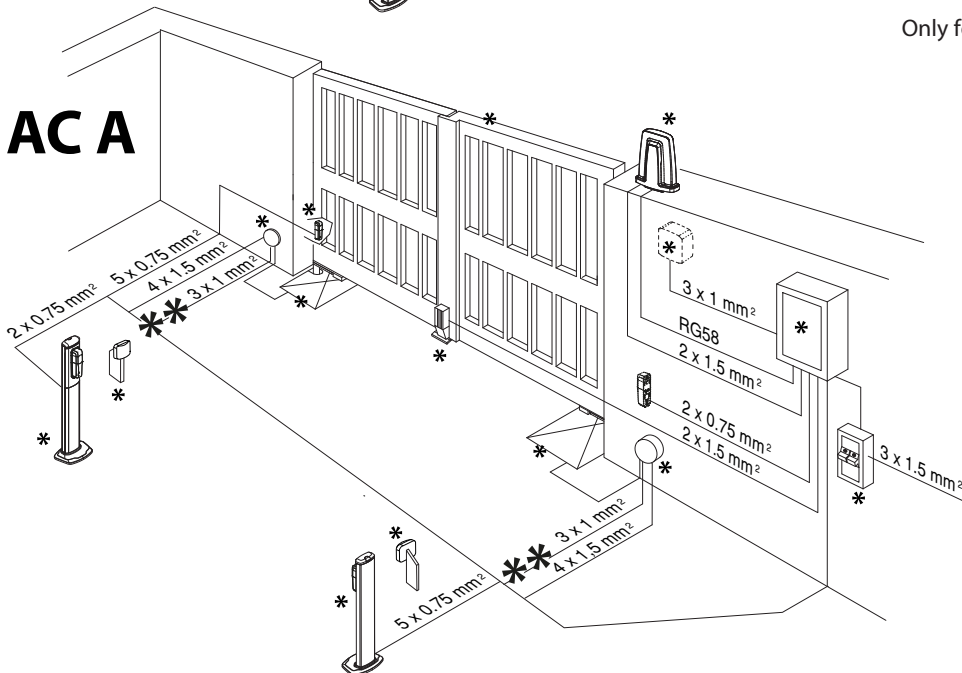

Not supplied

### PACKAGE CONTENTS

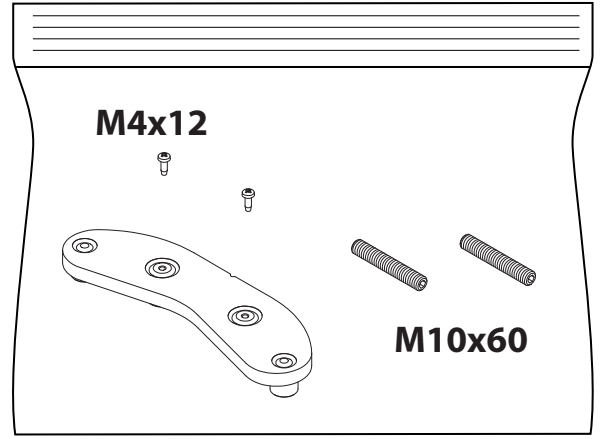
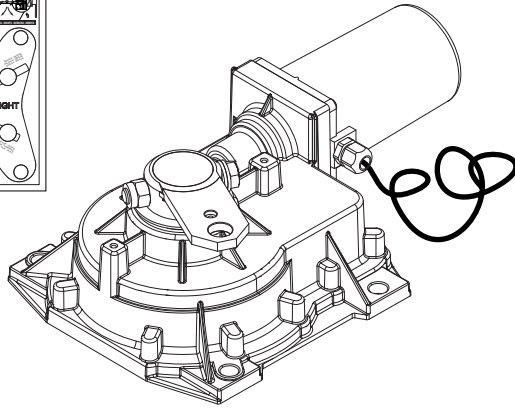
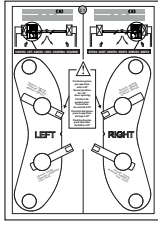

### EQUIPMENT NECESSARY

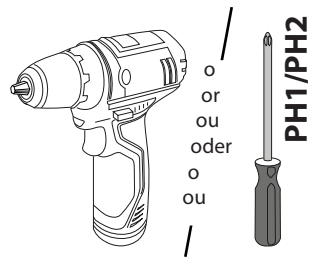
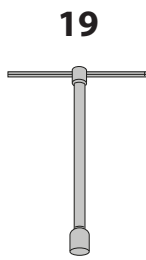

o  
or  
ou  
oder  
o  
ou  
/

PH1/PH2

**A**

### INSTALLATION ALTERNATIVE OPTIONS

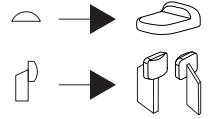

LEFT

RIGHT

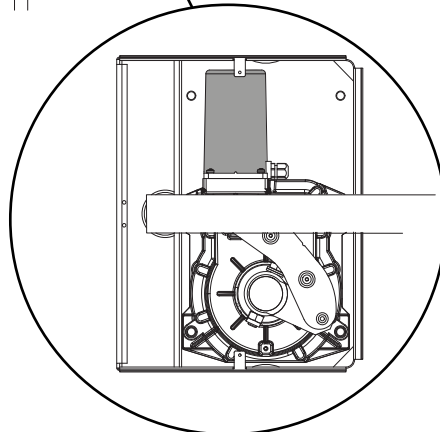
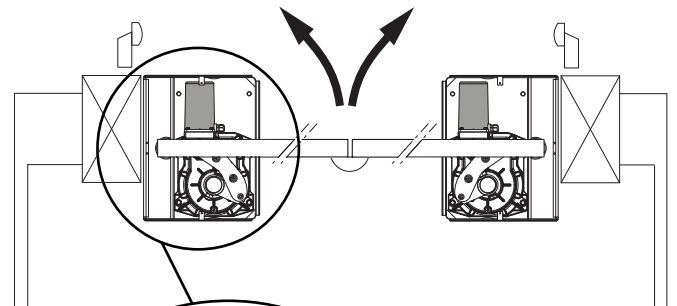
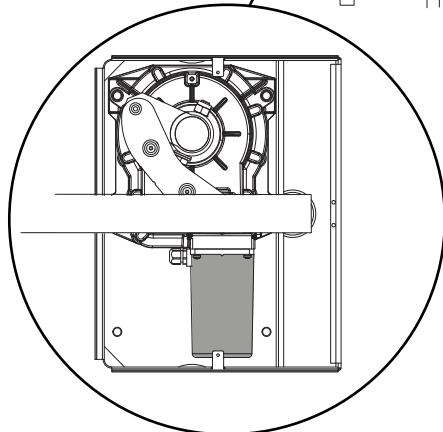
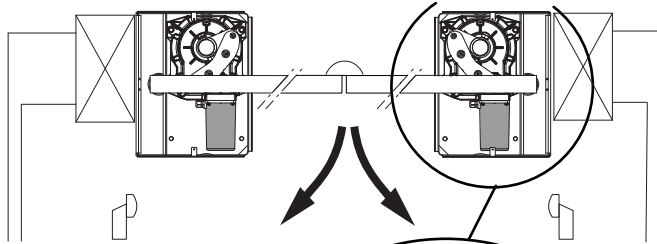

**B**

**INSTALLATION**

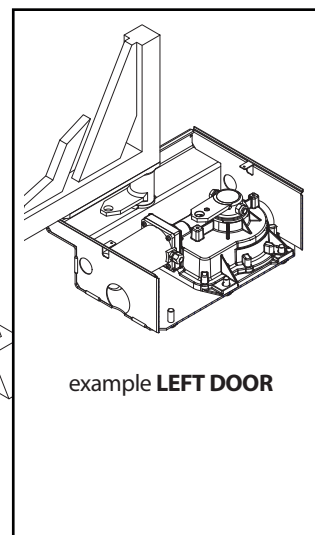
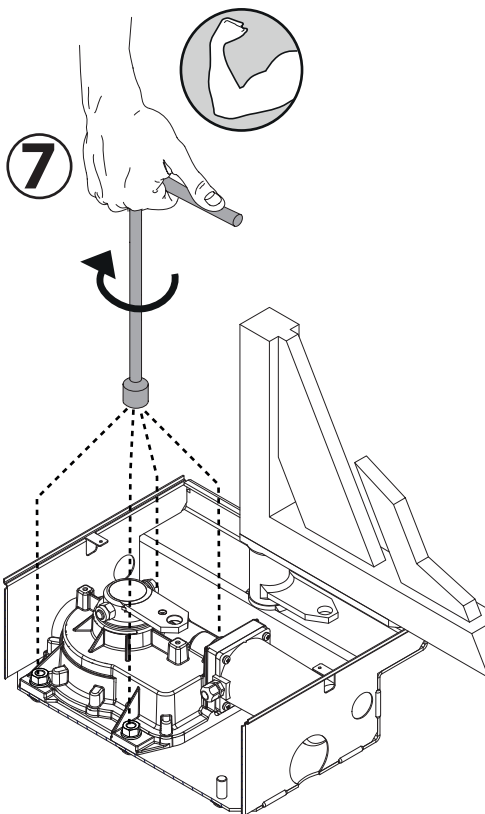
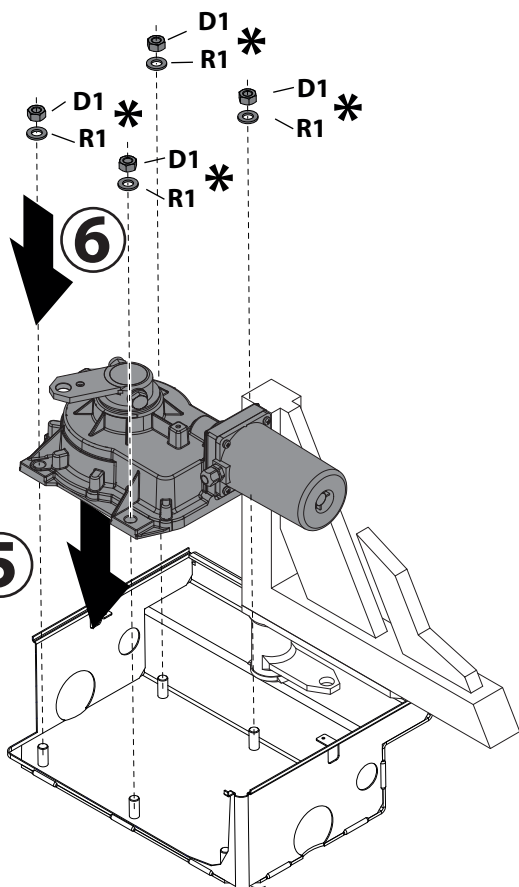
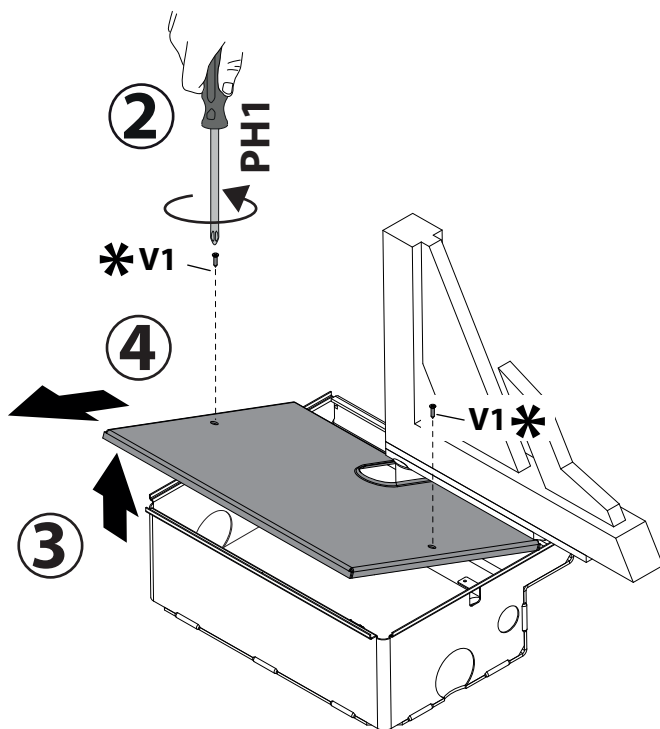
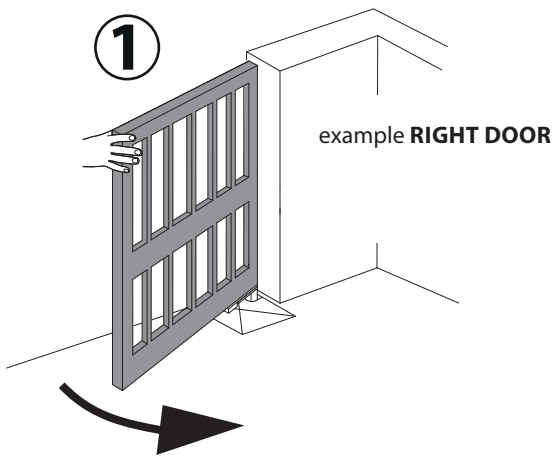

\* Provided in allocation with foundation casing

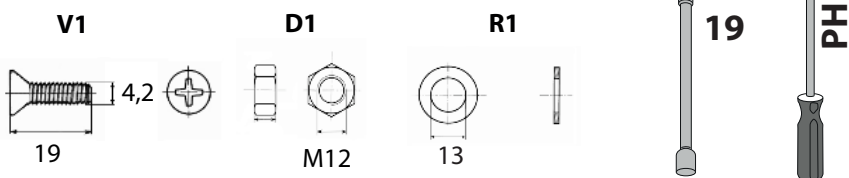

**C APPLICATION OF LABELS ABOUT THE INSTALLATION OF INTEGRATED END-STOPS**

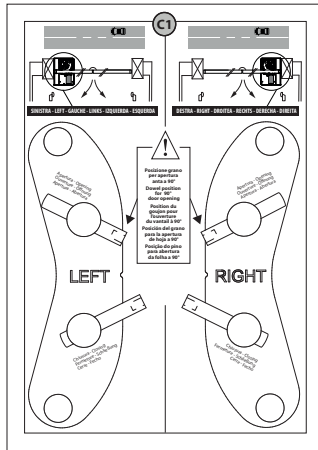

RIF. **C1**  
sheet supplied

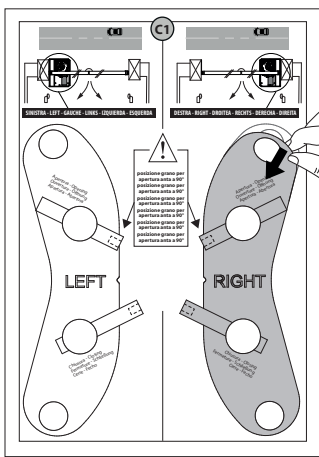

**1**

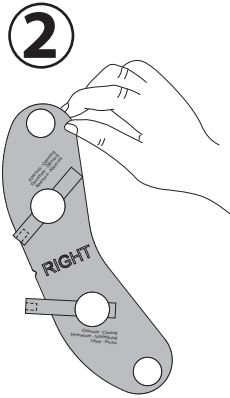

**2**

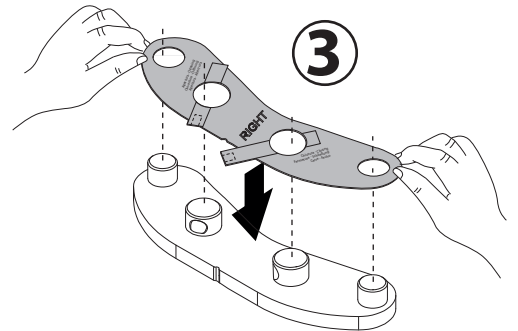

**3**

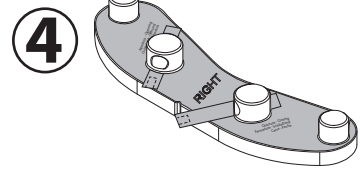

**4**

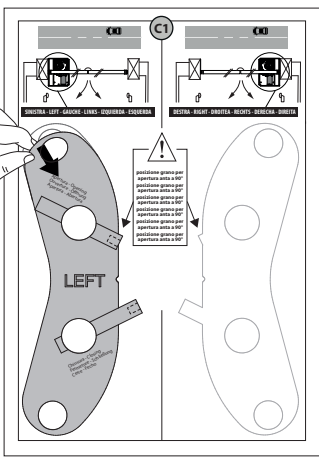

**5**

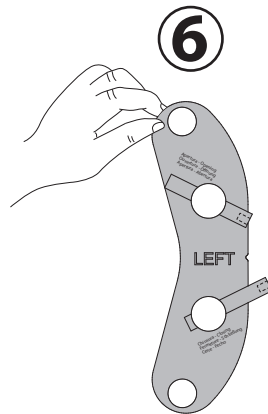

**6**

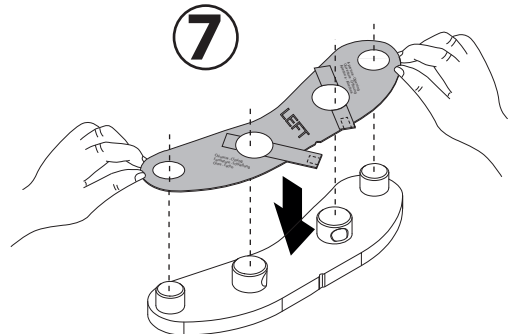

**7**

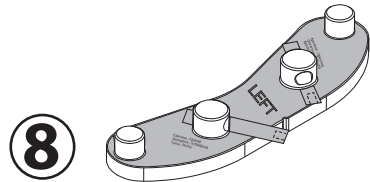

**8**

**D** APPLIED DIAGRAM FOR INTEGRATED END-STOPS

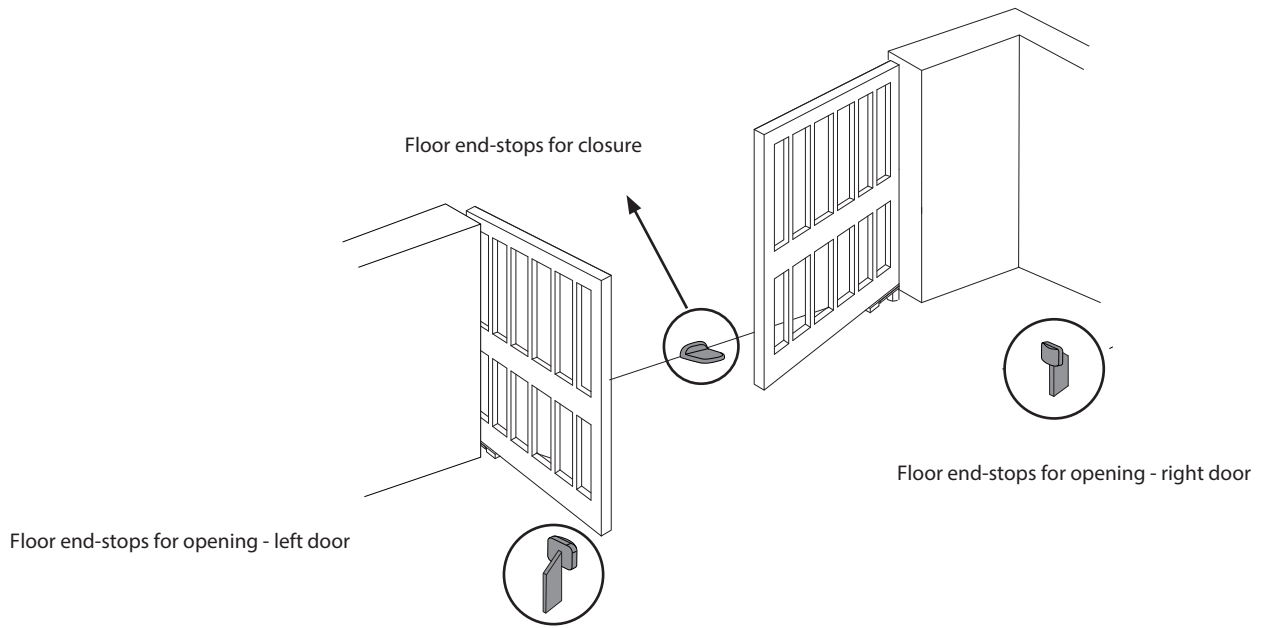

	INTEGRATED END-STOP LEFT DOOR	INTEGRATED END-STOP RIGHT DOOR
<b>D1</b> 		
<b>D2</b> 		
<b>D3</b> 		
<b>D4</b> 		



# EXAMPLE INSTALLATION OF INTEGRATED END-STOPS RIGHT DOOR

D2

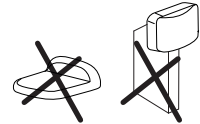

position of grub screw for 90° opening of the door

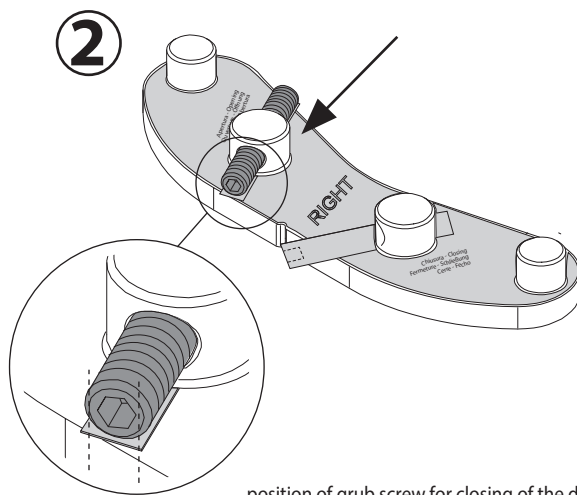
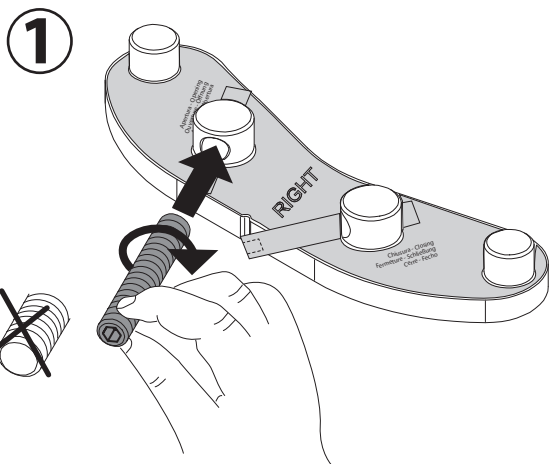

position of grub screw for closing of the door

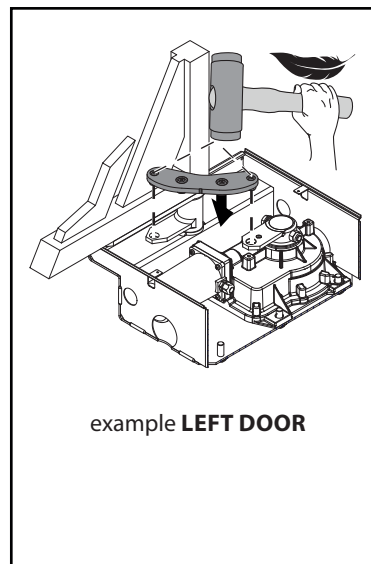
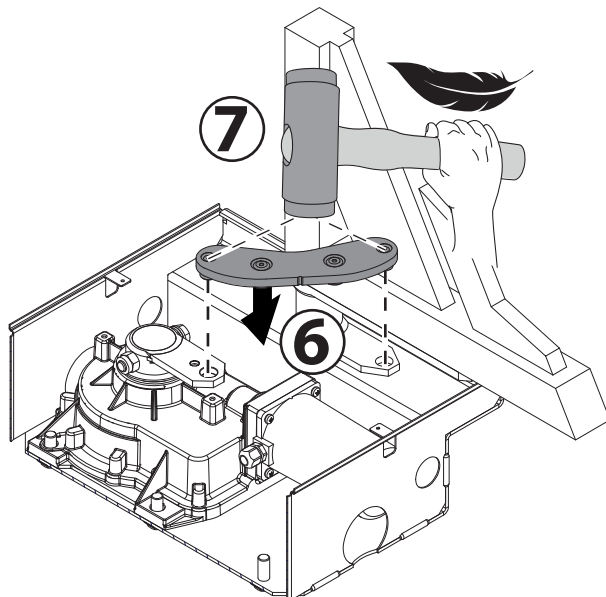
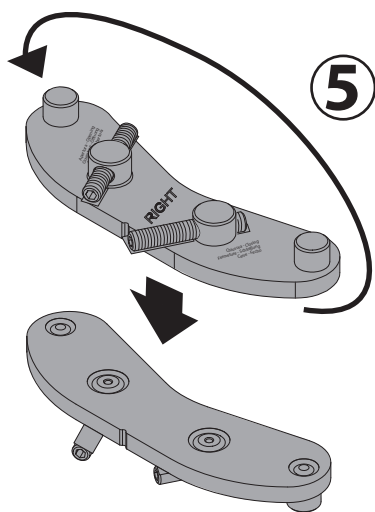
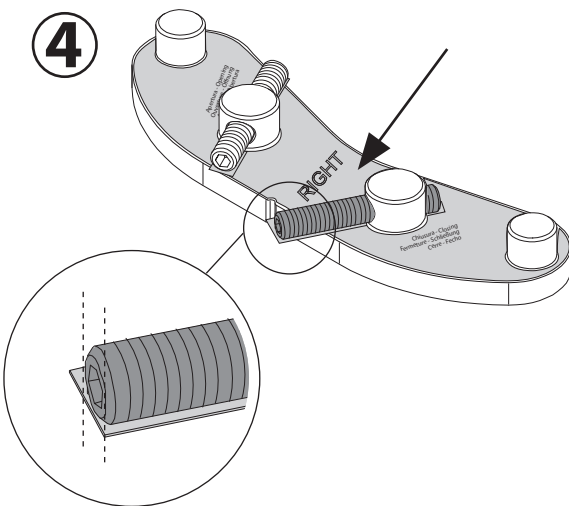
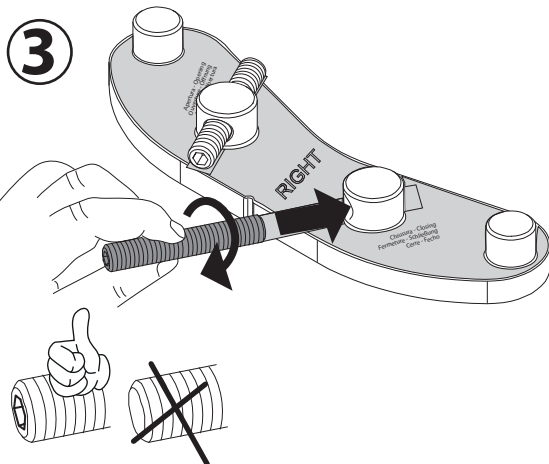



# ADJUSTMENT OF INTEGRATED END-STOPS RIGHT DOOR



5

Adjustment of grub screw for opening of right door

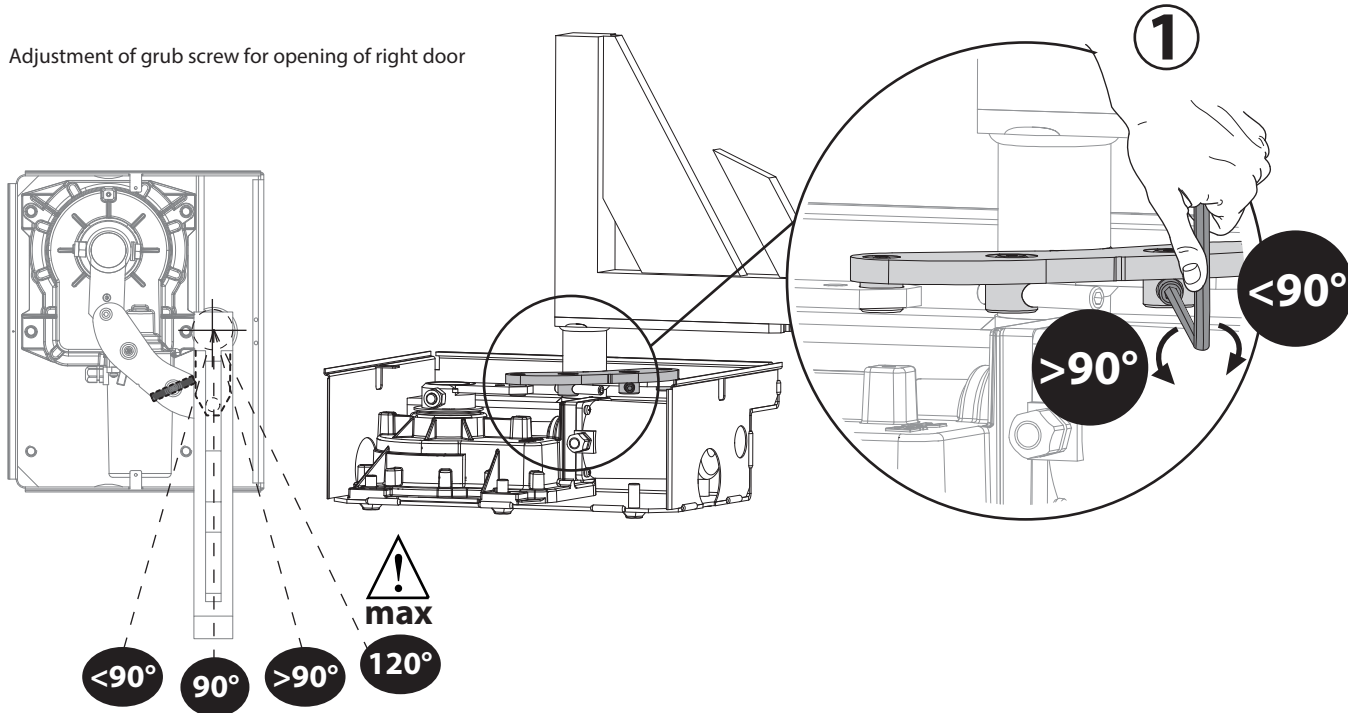

Adjustment of grub screw for closing of right door

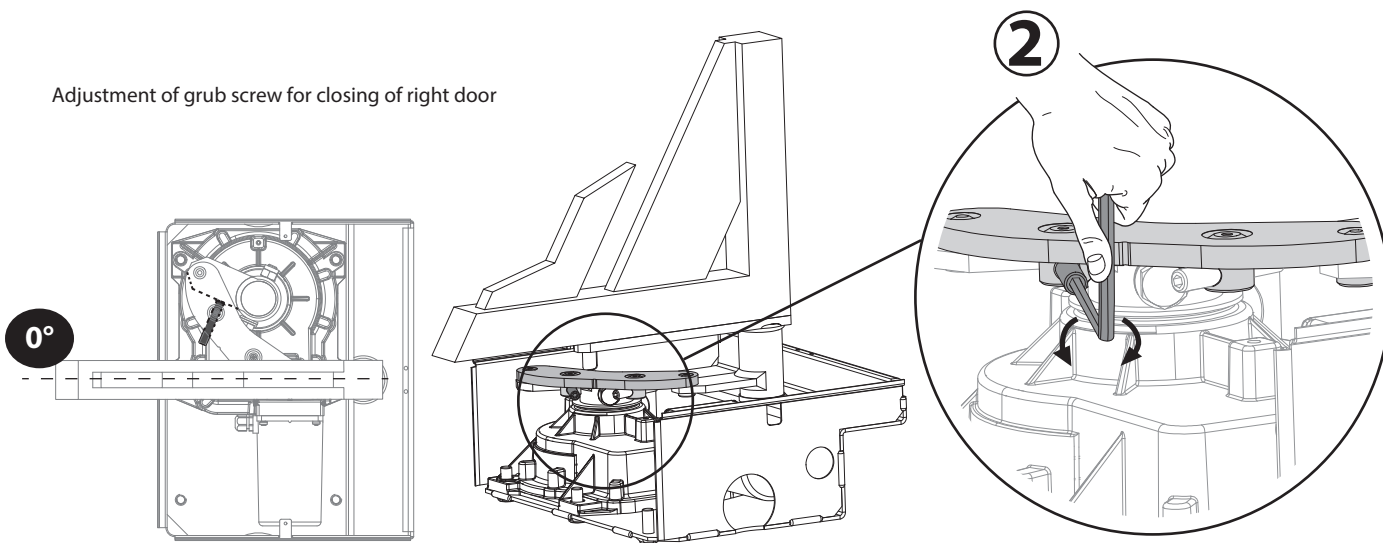

## FASTENING OF INTEGRATED END-STOPS

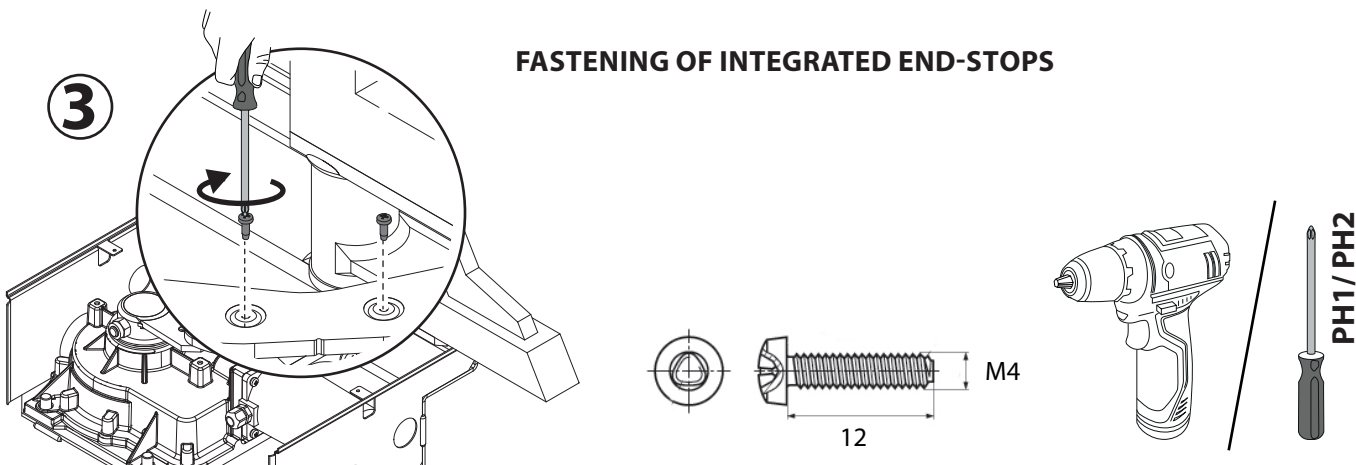



## ADJUSTMENT OF INTEGRATED END-STOPS LEFT DOOR



Adjustment of grub screw for opening of left door

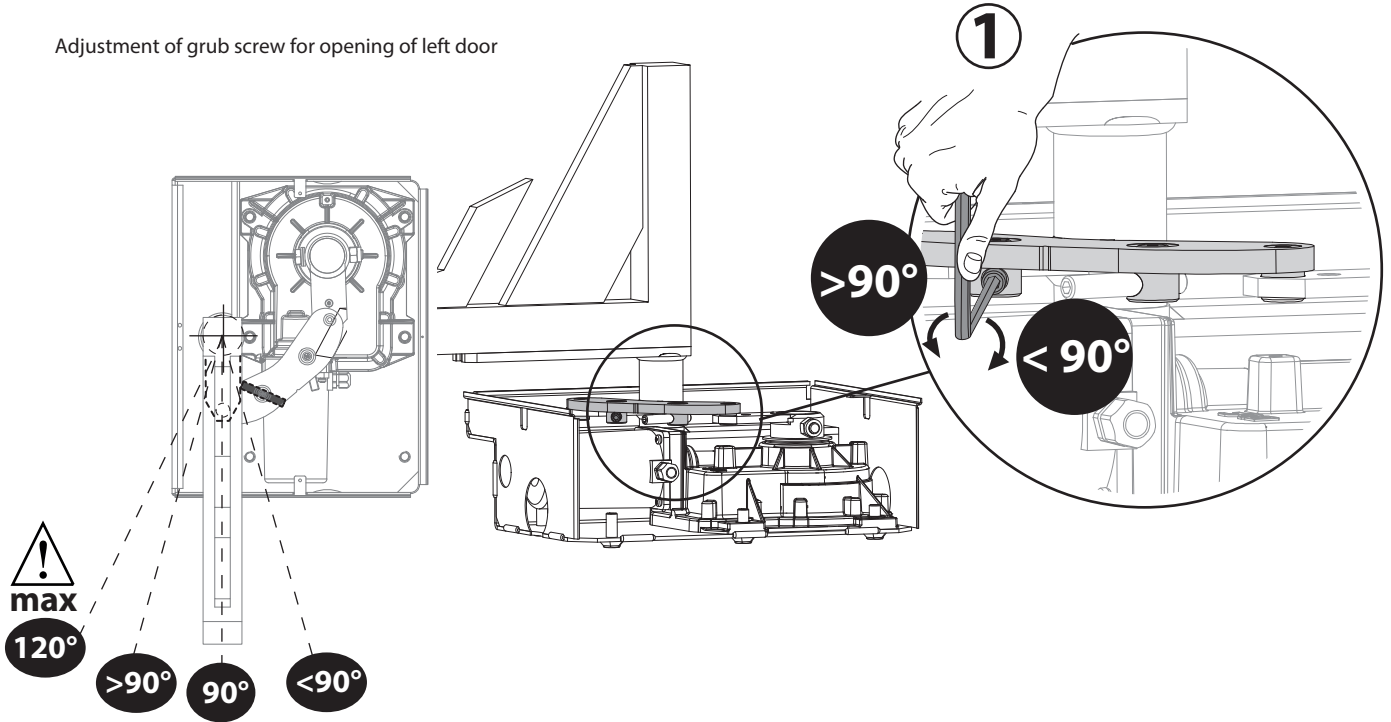

Adjustment of grub screw for closing of left door

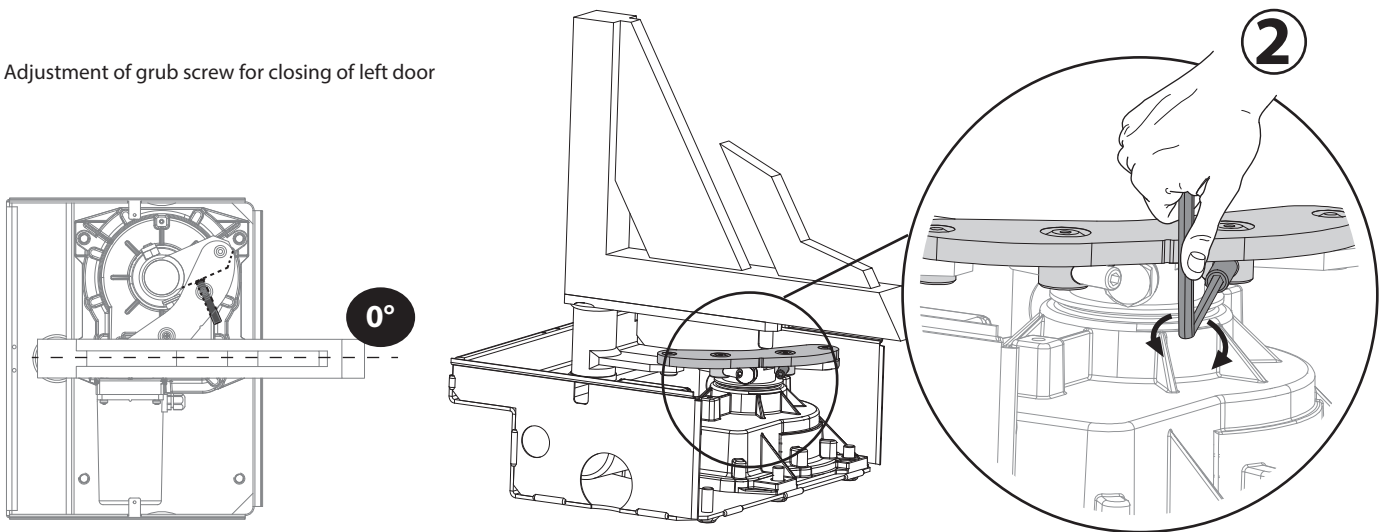

## FASTENING OF INTEGRATED END-STOPS

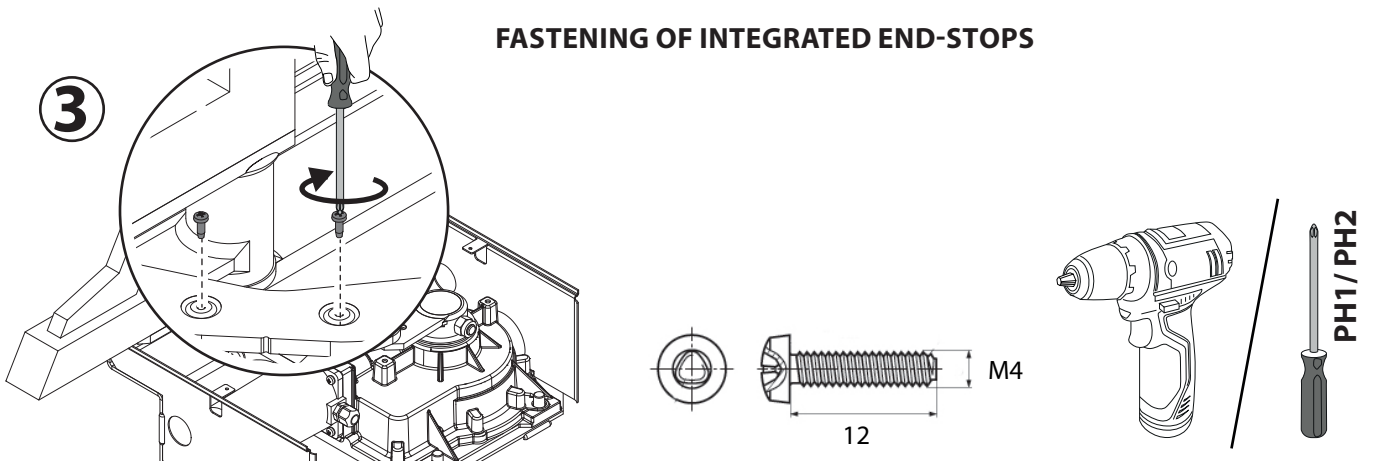

CONNECTIONS

H

ELI AC A

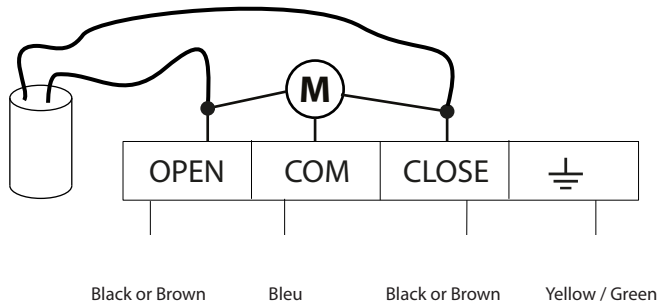

ELI BT A

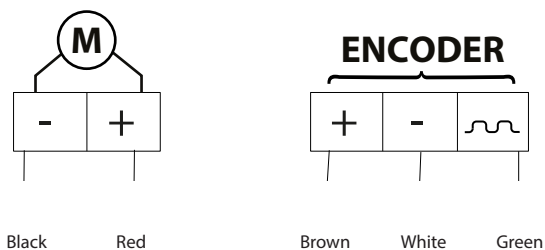

\*  
Not supplied

Junction box

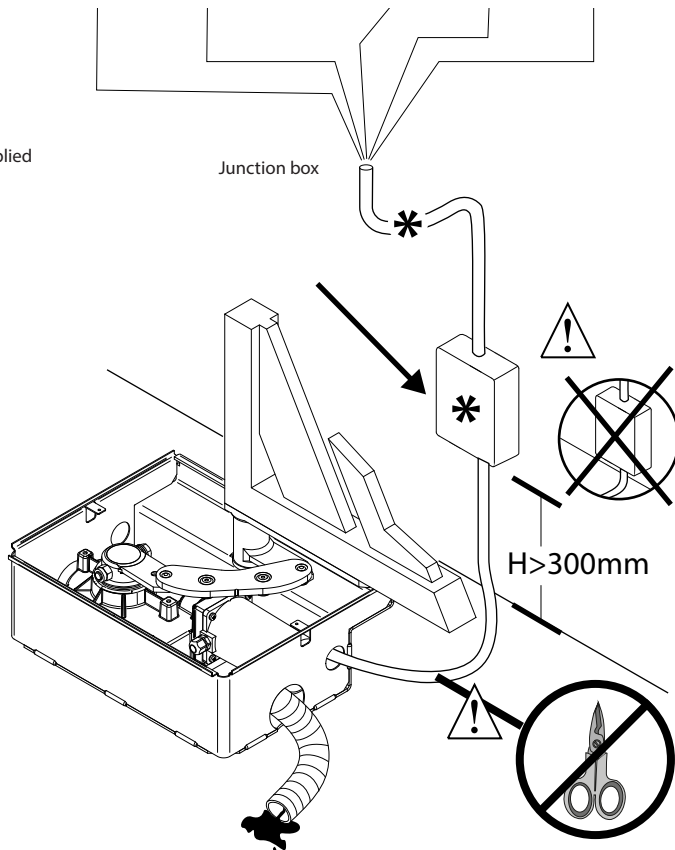
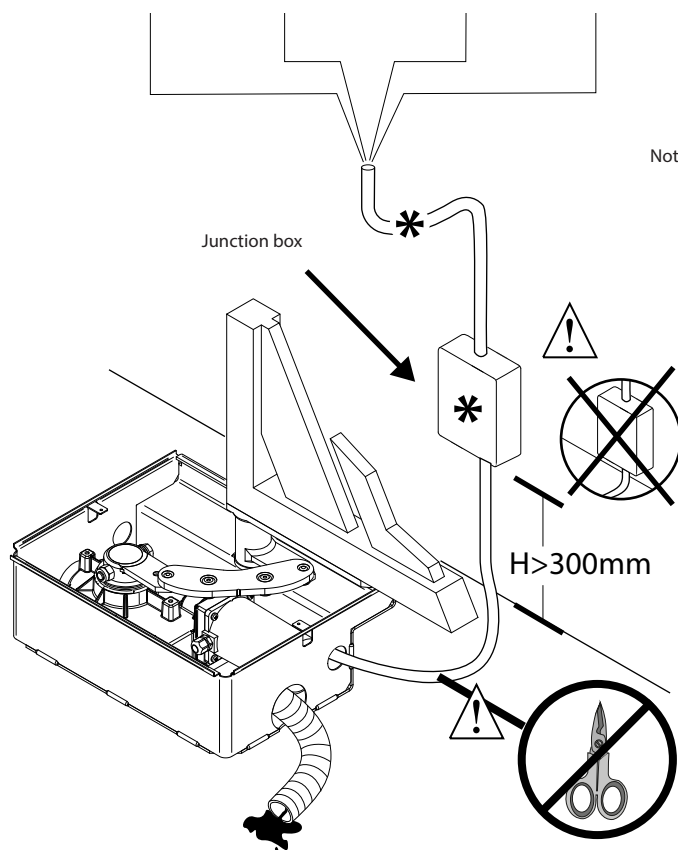

In order to comply with the regulatory obligations and to preserve the integrity of the installation, we recommend using slowdowns.

**I**

**BOX CLOSURE**

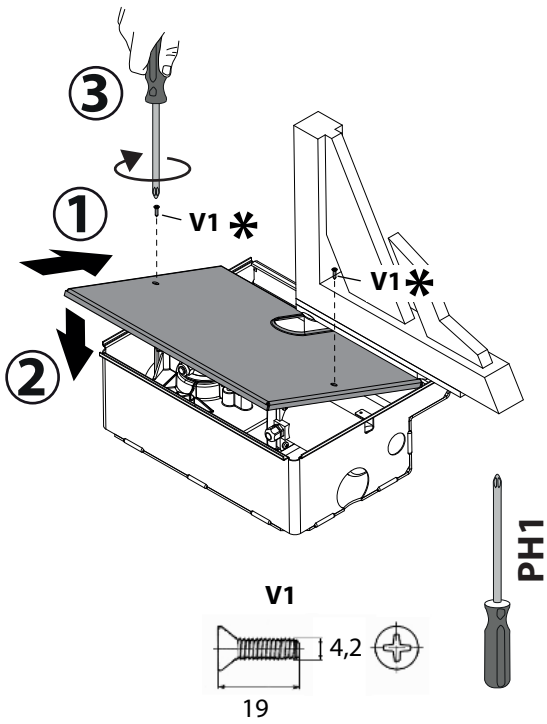

\*  
Provided in allocation with foundation casing

**L**

**MANUAL MANOEUVRE**

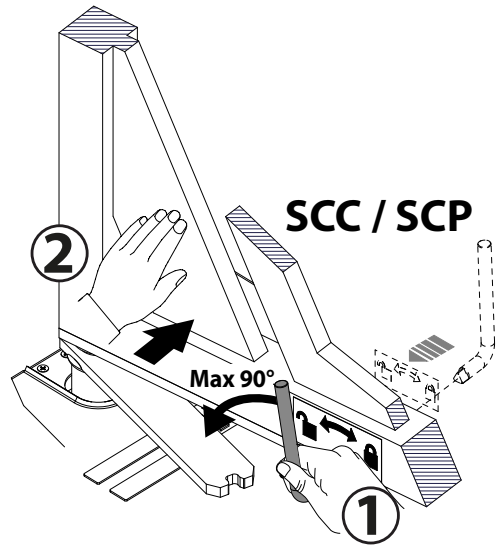

# LIMIT SWITCH ACCESSORY

## KIT COMPOSITION

2.9x13

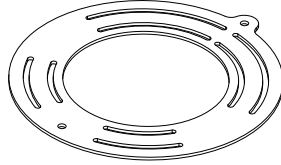
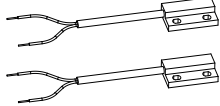

M4x8



## EQUIPMENT



**M**

For ELI BT A disconnect encoder from control unit



**1**

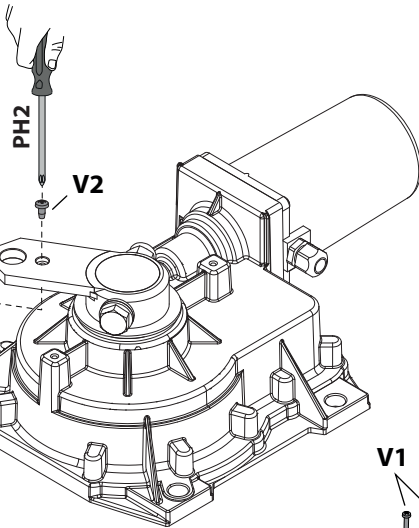

**2**

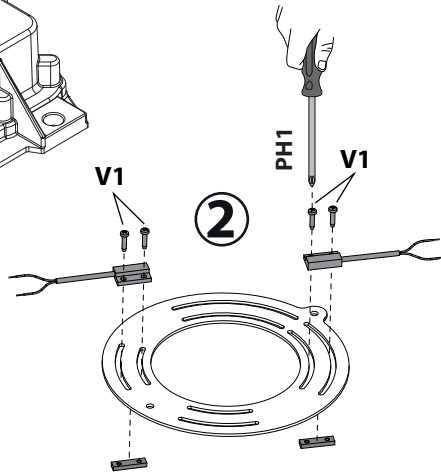

**3**

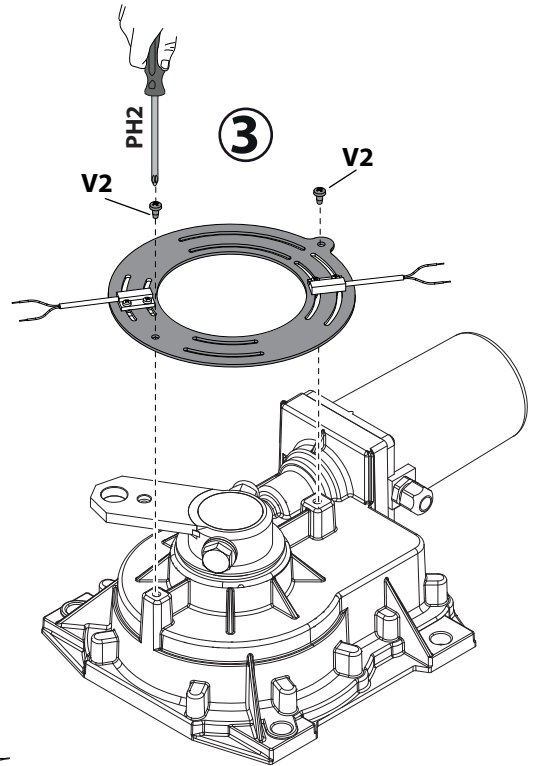

**4**

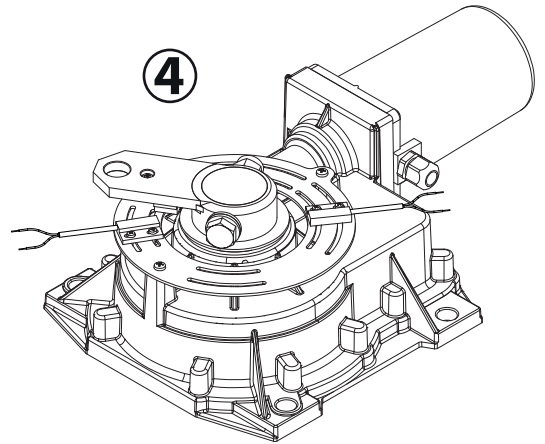

COM SWO SWC

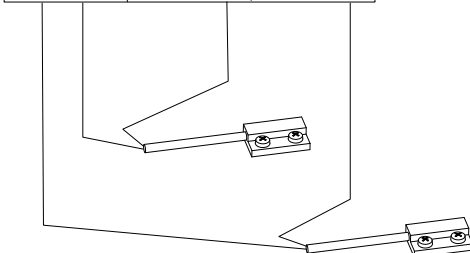

V1

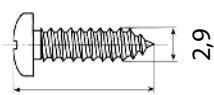

13

V2

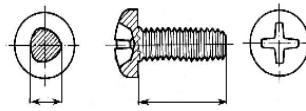

M4

8

## ENGLISH

TECHNICAL DATA	ELI AC A40	ELI AC A35 V	ELI BT A40	ELI BT A35 V
Motor power supply	220-230 Vac 50/60 Hz	220-230 Vac 50/60 Hz	24 Vdc	24 Vdc
Length of leaf for maximum weight	Fig.N			
Maximum leaf weight				
Maximum motor rpm	1.400	3.000	2.100	3.400
Operator angular exit speed with control unit without slowdown	1,03 rpm	2 rpm	1,45 rpm	2,5 rpm
Block holding: Irreversible geared motor; compulsory electro-lock for leafs length	> 2,5 m	> 2 m	> 2,5 m	> 2 m
Nominal power	300W	250W	180W	100W
Max. motor torque	350 Nm	250 Nm	350 Nm	200 Nm
Capacitor	10 $\mu$ F	8 $\mu$ F	-	-
Max. opening angle	120°			
Min. opening angle	45°			
Reaction to collision	electronic clutch (with control panel)			
Manual manoeuvre	release key			
Thermal protection	160°C self reset	-	-	-
Environmental conditions	-20° / +55°C			
Lubrication	permanent grease			
Degree of protection	IP67			
Actuator weight	120 N (12kg)	120 N (12kg)	100 N (10kg)	95 N (9,5kg)

\* special voltage supplies on request

	ELI AC A40			ELI AC A35 V			ELI BT A40			ELI BT A35 V		
Operating temperature range	+20°C	+40°C	+55°C	+20°C	+40°C	+55°C	+20°C	+40°C	+55°C	+20°C	+40°C	+55°C
Cycle of use (the cycles refer to 90° travel)	40 cycles/h	30 cycles/h	20 cycles/h	60 cycles/h	50 cycles/h	40 cycles/h	ciclo continuo			50 cycles/h		

N

### ELI AC A35 V / ELI BT A35 V

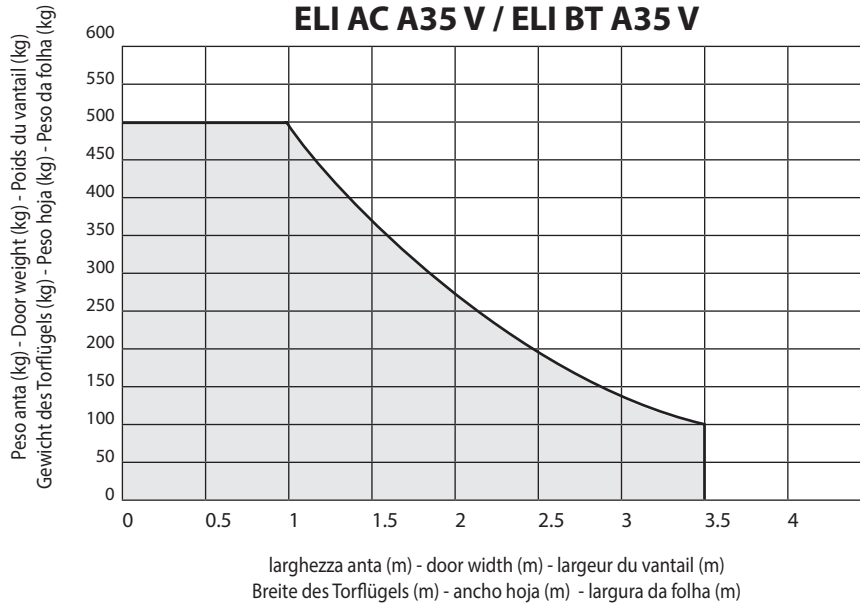

### ELI AC A40 / ELI BT A40

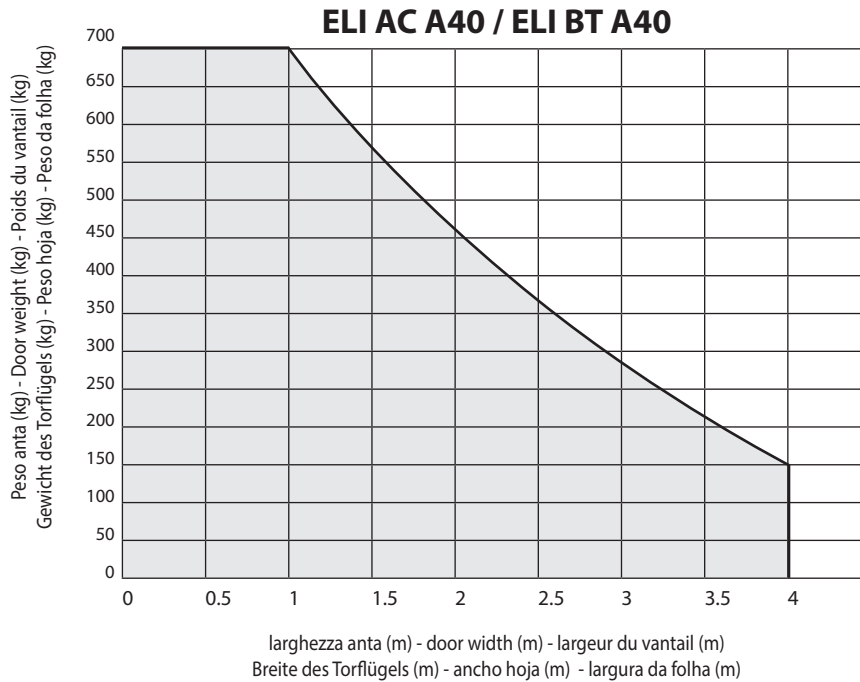

**BFT Spa** [www.bft-automation.com](http://www.bft-automation.com)  
Via Lago di Vico, 44 **ITALY**  
36015 Schio (VI)  
T +39 0445 69 65 11  
F +39 0445 69 65 22



**SPAIN** [www.bftautomatismos.com](http://www.bftautomatismos.com)  
**BFT GROUP ITALIBERICA DE AUTOMATISMOS S.L.**  
08401 Granollers - (Barcelona)

**FRANCE** [www.bft-france.com](http://www.bft-france.com)  
**AUTOMATISMES BFT FRANCE**  
69800 Saint Priest

**GERMANY** [www.bft-torantriebe.de](http://www.bft-torantriebe.de)  
**BFT TORANTRIEBSSYSTEME GmbH**  
90522 Oberasbach

**BENELUX** [www.bftbenelux.be](http://www.bftbenelux.be)  
**BFT BENELUX SA**  
1400 Nivelles

**UNITED KINGDOM** [www.bft.co.uk](http://www.bft.co.uk)  
**-BFT Automation UK Limited**  
Unit C2-C3, The Embankment Business Park, Vale Road, Heaton Mersey, Stockport, SK4 3GL

**-BFT Automation (South) Limited**  
Enterprise House, Murdock Road, Dorcan, Swindon, SN3 5HY

**PORTUGAL** [www.bftportugal.com](http://www.bftportugal.com)  
**BFT SA - COMERCIO DE AUTOMATISMOS E MATERIAL DE SEGURANCIA**  
3026-901 Coimbra

**POLAND** [www.bft.pl](http://www.bft.pl)  
**BFT POLSKA SP.ZO.O.**  
Marecka 49, 05-220 Zielonka

**IRELAND** [www.bftautomation.ie](http://www.bftautomation.ie)  
**BFT AUTOMATION LTD**  
Unit D3, City Link Business Park, Old Naas Road, Dublin 12

**CROATIA** [www.bft.hr](http://www.bft.hr)  
**BFT ADRIA D.O.O.**  
51218 Drazice (Rijeka)

**CZECH REPUBLIC** [www.bft.it](http://www.bft.it)  
**BFT CZ S.R.O.**  
Praha

**TURKEY** [www.bftotomasyon.com.tr](http://www.bftotomasyon.com.tr)  
**BFT OTOMATIK KAPI SISTEMELERI SANAY VE**  
Istanbul

**RUSSIA** [www.bftrus.ru](http://www.bftrus.ru)  
**BFT RUSSIA**  
111020 Moscow

**AUSTRALIA** [www.bftaustralia.com.au](http://www.bftaustralia.com.au)  
**BFT AUTOMATION AUSTRALIA PTY LTD**  
Wetherill Park (Sydney)

**U.S.A.** [www.bft-usa.com](http://www.bft-usa.com)  
**BFT USA**  
Boca Raton

**CHINA** [www.bft-china.cn](http://www.bft-china.cn)  
**BFT CHINA**  
Shanghai 200072

**UAE** [www.bftme.ae](http://www.bftme.ae)  
**BFT Middle East FZCO**  
Dubai